

Install the spring over the spindle. Insert each end of the cutting line through the eyelets in the cutting head assembly and lower the spool while feeding the line as illustrated in Fig 16.

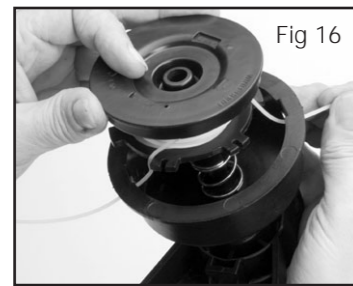

Once the spool is in place, apply pressure on the spool compressing the spring. Pull each end of the line sharply to unlock the line from the slots. Continue to apply pressure to the spool until the knob can be threaded clockwise onto the spindle. Tighten the knob securely. Fig 17.



AIR FILTER

It is recommended that the air filter is cleaned on a regular basis. To clean the air filter, depress the air filter cover latch and remove the cover. Fig 18.

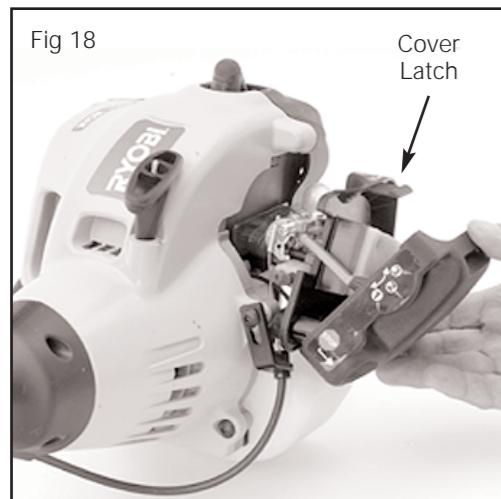

Remove and wash the filter with soap and water. Allow to completely air dry before replacing the filter. After replacing the filter secure the air filter cover.

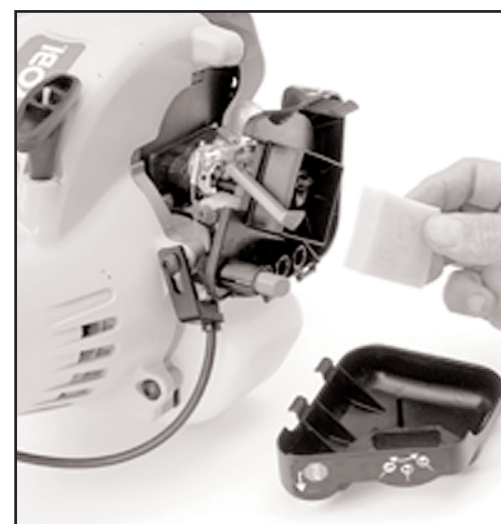

CLEANING & STORAGE



WARNING: Always turn off your trimmer before you clean or perform maintenance on it. Failure to do so could result in serious personal injury.

Use a small brush to clean off the outside of the trimmer. Do not use strong detergents on plastic housing or handle, as they can be damaged by household cleaners that contain aromatic oils such as pine or lemon and by solvents such as kerosene. Wipe off any moisture with a soft cloth.

STORAGE

If the trimmer will be stored for an extended period of time, use the following storage procedure:

1. Drain all fuel from the fuel tank into a container.
2. Start the motor and allow it to run until it stalls. This ensures that all the fuel has been drained from the carburetor.
3. Allow the motor to cool. Remove the spark plug and put approximately 30ml of any high quality oil or 2 stroke oil into the cylinder. Pull the starter rope slowly to distribute the oil. Reinstall the spark plug. Leave the spark plug wire off for storage.
4. Inspect for any damaged or loose parts. Repair or replace any damaged parts and tighten loose screws, nuts or bolts.

RYOBI TECHNOLOGIES AUSTRALIA PTY. LTD.

GUARANTEE



Subject to the guarantee condition below, this Ryobi tool (hereinafter called "the product") is guaranteed by Ryobi (hereinafter called "the Company") to be free from defects in material or workmanship for a period of 12 months from the date of original purchase covering both parts and labour. Under the terms of this guarantee, the repair or replacement of any part shall be the opinion of the Company or its authorised agent. Should service become necessary during the guarantee period, the owner should contact the Authorised Ryobi Retailer from whom the Product was purchased, or the nearest Company Branch Office. In order to obtain guarantee service, the owner must present the sales docket and Guarantee Certificate to confirm date of purchase. This product is sold by the dealer or agent as principal and the dealer has no authority from the Company to give any additional guarantee on the Company's behalf except as herein contained or herein referred to.

Guarantee Conditions

This guarantee only applies provided that the Product has been used in accordance with the manufacturer's recommendations under normal use and reasonable care (in the opinion of the Company) and such guarantee does not cover damage, malfunction or failure resulting from misuse, neglect, abuse, or used for a purpose for

which it was not-designed or is not suited; and no repairs, alterations or modifications have been attempted by other than an Authorised Service Agent. This guarantee will not apply if the tool is damaged by accident or if repairs arise from normal wear and tear.

The Company accepts no additional liability pursuant to this guarantee for the costs of travelling or transportation of the Product or parts to and from the service dealer or agent - which costs are not included in this guarantee.

Certain legislation, including the Trade Practices Act, 1974 (as amended) and other state and territorial laws give rights to the buyer and impose liability on the seller in certain circumstances. Nothing herein shall have the effect of excluding, restricting or modifying any condition, guarantee, right or liability imposed, to the extent only that such exclusion, restriction or modification would render any term herein void.

RYOBI

RYOBI TECHNOLOGIES AUSTRALIA PTY. LTD.

A.C.N. 002 277 509 Incorporated in N.S.W.
SYDNEY: 359-361 Horsley Road, Milperra, N.S.W.
 2214, Phone: (02) 9772 2444
 email: info@ryobi.aust.com

MELBOURNE: 960 Stud Road, Rowville, Vic, 3178,
 Phone: (03) 9764 8655

HOBART: All Enquiries Phone: 1300 361 505

BRISBANE: All Enquiries Phone: 1300 361 505

PERTH: 33-35 Sorbonne Crescent, Canning Vale,
 WA, 6155, Phone: (08) 9455 7775

ADELAIDE: All Enquiries Phone: 1300 361 505

TOWNSVILLE: All Enquiries Phone: 1300 361 505

RYOBI TECHNOLOGIES NEW ZEALAND LIMITED

Auckland: 503 Mt Wellington Highway,
 Mt Wellington, NZ, Phone: (09) 573 0230
 email: info@ryobi.co.nz

THIS GUARANTEE FORM SHOULD BE RETAINED BY THE CUSTOMER AT ALL TIMES

For your record and to assist in establishing date of purchase (necessary for in-guarantee service) please keep your purchase docket and this form completed with the following particulars.

PURCHASED FROM _____

ADDRESS OF DEALER _____

DATE _____ MODEL NO _____ SERIAL NO _____

Present This Form With Your Purchase Docket When Guarantee Service Is Required

RYOBI

OWNER'S OPERATING MANUAL GRASS TRIMMER MODEL RGT2500



SPECIFICATION

Motor25cc 2 Stroke
 IgnitionElectronic
 CarburetorDiaphragm, all position
 Cutting HeadTwin line bump feed
 Cutting Line2.0 mm
 Width Of Cut43 cm
 Fuel Mixture:25:1
 Weight4.8 kg

THANK YOU FOR BUYING A RYOBI TRIMMER.

Your new Trimmer has been engineered and manufactured to Ryobi's high standard for dependability, ease of operation, and operator safety. Properly cared for, it will give you years of rugged, trouble free performance.

CAUTION: Carefully read through this entire owner's manual before using your new Trimmer.

Pay close attention to the Rules for Safe Operation, Warnings and Cautions. If you use your Trimmer properly and only for what it is intended, you will enjoy years of safe, reliable service.

Thank You again for buying Ryobi tools.

RULES FOR SAFE OPERATION

The purpose of safety rules is to attract your attention to possible dangers. The safety symbols and the explanations with them, require your careful attention and understanding. The safety warnings do not by themselves eliminate any danger. The instruction or warnings they give are not substitutes for proper accident prevention measures.

SAFETY ALERT SYMBOL. Indicates caution or warning. May be used in conjunction with other symbols or pictures.

WARNING: Failure to obey a safety warning can result in serious injury to yourself or to others. Always follow the safety precautions to reduce the risk of fire, electric shock and personal injury.

WARNING: Do not attempt to operate this tool until you have read thoroughly and understood completely, safety rules, etc. contained in this manual. Failure to comply can result in accidents involving fire, electric shock or serious personal injury. Save owners manual and review frequently for continuing safe operation and instructing others who may use this tool.

WEAR YOUR SAFETY GOGGLES
FORESIGHT IS BETTER THAN NO SIGHT

The operation of any tool can result in foreign objects being thrown into your eyes, which can result in severe eye damage. Before beginning power tool operation, always wear safety goggles or safety glasses with side shields and a full face shield when needed. We recommend Wide Vision Safety Mask for use over eyeglasses or standard safety glasses with side shields.

- 1. KNOW YOUR POWER TOOL.** Read owners manual carefully. Learn its applications and limitations as well as the specific potential hazards related to this tool.
- 2. GUARD AGAINST ELECTRICAL SHOCK BY PREVENTING BODY CONTACT WITH GROUNDED SURFACES.** For example, pipes, radiators, ranges, refrigerator enclosures.
- 3. KEEP WORK AREA CLEAN.** Cluttered areas and benches invite accidents.
- 4. AVOID DANGEROUS ENVIRONMENT.** Don't use power tools in damp or wet locations or expose to rain. Keep work area well lit.
- 5. KEEP CHILDREN AND VISITORS AWAY.** Visitors should wear safety glasses and be kept a safe distance from work area. Do not let visitors contact tool or extension cord.
- 6. STORE IDLE TOOLS.** When not in use, tools should be stored in a dry and high or locked-up place, out of reach of children.
- 7. DON'T FORCE TOOL.** It will do the job better and safer at the rate at which it was designed.
- 8. USE RIGHT TOOL.** Don't force small tool or attachment to do the job of a heavy duty tool. Don't use tool for purpose not intended.
- 9. DRESS PROPERLY.** Do not wear loose clothing or jewellery. They can be caught in moving parts. Rubber gloves and non-skid footwear are recommended when working outdoors. Also wear protective hair covering to contain long hair.

- 10. ALWAYS WEAR SAFETY GLASSES.** Everyday eyeglasses have only impact resistant lenses, they are not safety glasses.
- 11. PROTECT YOUR LUNGS.** Wear a dust mask if operation is dusty.
- 12. PROTECT YOUR HEARING.** Wear hearing protection during extended periods of operation.
- 13. DON'T OVERREACH.** Keep proper footing and balance at all times. Do not use tool on a ladder or unstable support. Secure tools when working at elevated levels.
- 14. MAINTAIN TOOLS WITH CARE.** Keep tools sharp and clean for better and safer performance. Follow instructions for lubricating and changing accessories.
- 15. REMOVE ADJUSTING KEYS AND WRENCHES.** Form a habit of checking to see that keys and adjusting wrenches are removed from tool before turning it on.
- 16. NEVER USE IN AN EXPLOSIVE ATMOSPHERE.** Normal sparking of the motor could ignite fumes.
- 17. KEEP HANDLES DRY, CLEAN AND FREE FROM OIL AND GREASE.** Always use a clean cloth when cleaning. Never use brake fluids, gasoline, petroleum based products, or any strong solvents to clean your tool.
- 18. STAY ALERT AND EXERCISE CONTROL.** Watch what you are doing and use common sense. Do not operate tool when you are tired. Do not rush.
- 19. CHECK DAMAGED PARTS.** Before further use of the tool, a guard or any other part that is damaged should be carefully checked to determine that it will operate properly and perform its intended function. Check for alignment of moving parts, binding of moving parts, breakage of parts, mounting and any other conditions that may affect its operation. A guard or any other part that is damaged should be properly repaired or replaced by an authorised service centre.
- 20. DO NOT USE TOOL IF SWITCH DOES NOT TURN IT ON AND OFF.** Have defective switches replaced by authorised service centre.
- 21. DO NOT OPERATE THIS TOOL WHILE UNDER THE INFLUENCE OF DRUGS, ALCOHOL OR ANY MEDICATION.**

SAVE THESE INSTRUCTIONS FOR FUTURE REFERENCE

Due to Ryobi's continued product refinement policy, product features and specifications can and will change without notice. Check current features and specifications with your Ryobi retailer.

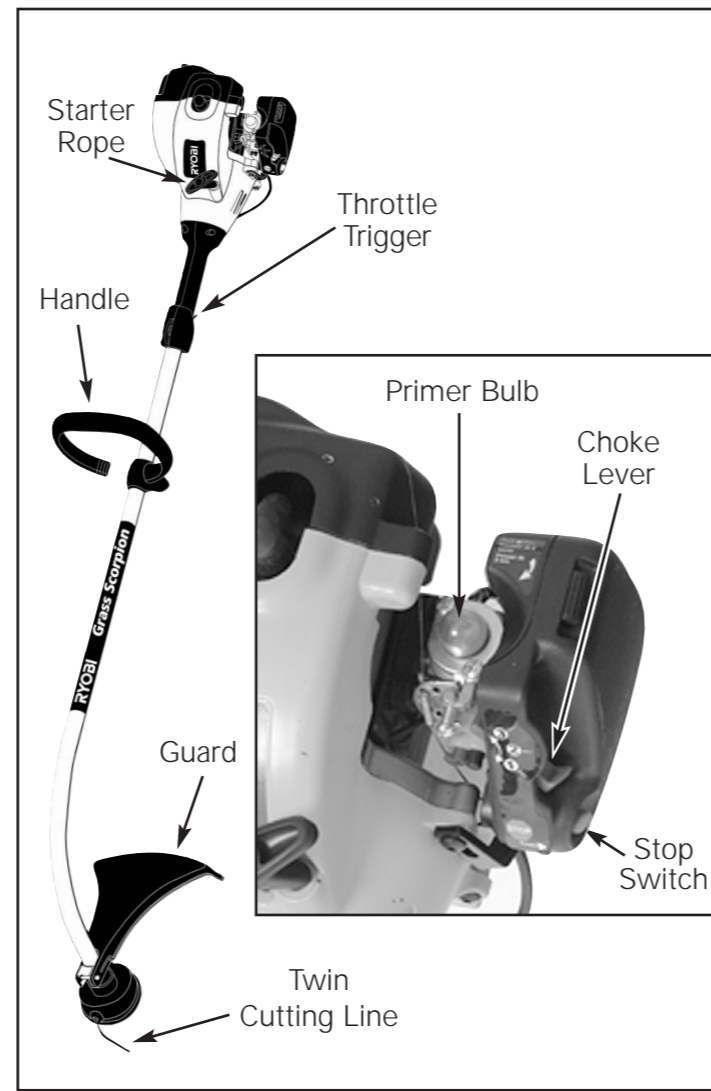

ASSEMBLY

HANDLE Fig 1. Push the handle down over the shaft.

Insert the bolt and wing nut and tighten gently.

Adjust the handle to the desired height and tighten wing nut securely.

GUARD Fig 2. Push the guard onto the shaft clamp assembly. Align the 2 holes in the guard with the 2 recesses in the clamp assembly. Secure with bolt washer, lock washer and wing nut supplied.

WARNING: To avoid serious personal injury, never operate the trimmer without the guard in place.

OIL & FUEL MIXTURE
Thoroughly mix 200ml of 2 stroke oil to 5 litres of unleaded petrol in a container and fill the trimmer fuel tank. Fig 3
Care should be taken not to overfill the fuel tank which will result in fuel splashing onto engine parts.

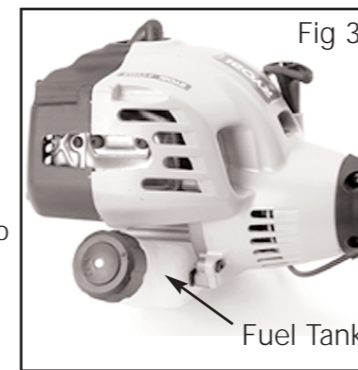

WARNING: Always stop the motor and allow it to cool before re-filling the fuel tank. Failure to adhere to this warning can result in vapour explosion causing serious personal injury.

WARNING: Always mix petrol and oil in a separate container. Do not mix directly in the trimmer fuel tank which will cause motor damage and void the warranty.

STARTING INSTRUCTIONS FOLLOW STEPS A, B, C.
Place the choke lever in the "Full Choke" position. Fig 4

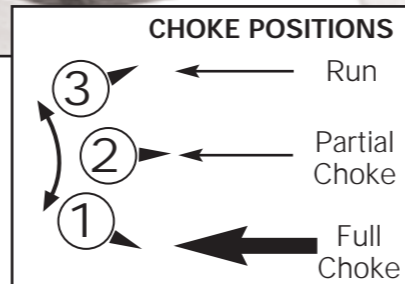
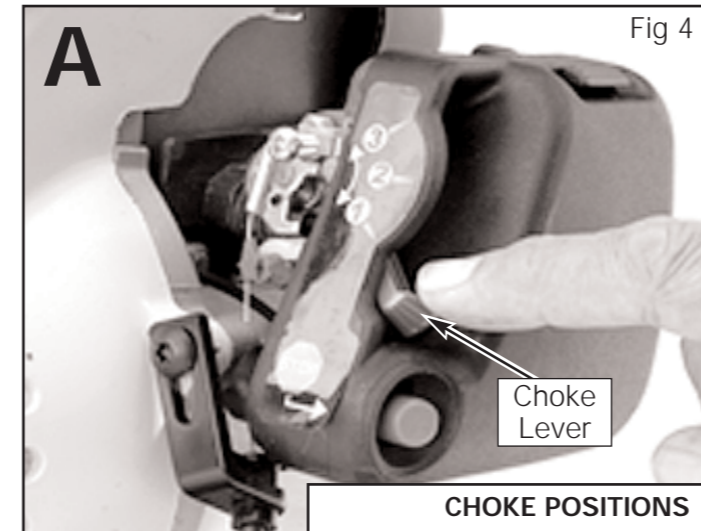

Fully depress and release the primer bulb 5 to 7 times. Fuel should be visible in the bulb. Fig 5

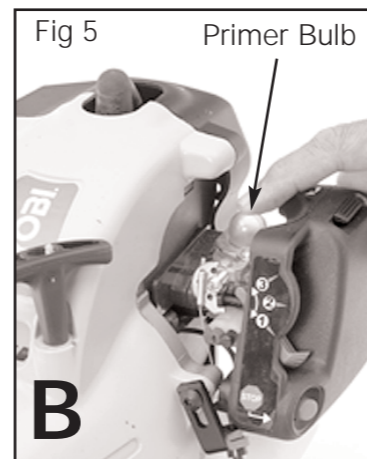

With the trimmer on the ground, squeeze the throttle trigger fully and pull the starter rope briskly until the motor sounds like it wants to start Fig 6.

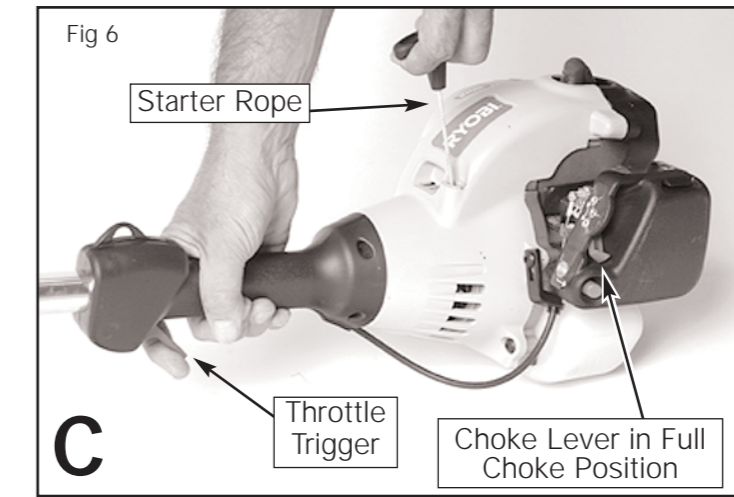

Place the choke lever in the "Partial Choke" position. Fig 7. Keep the throttle trigger depressed at all times. Pull the starter rope briskly 1 to 3 times to start the motor.

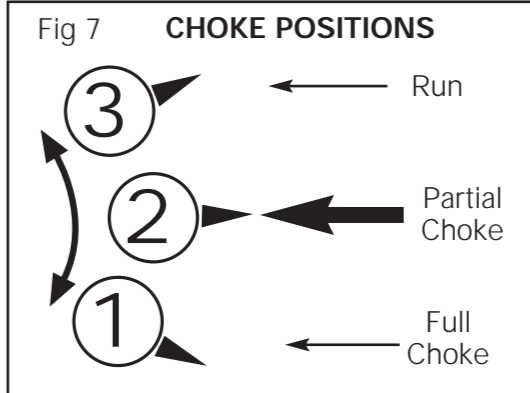

If motor fails to start, repeat steps 5 to 7

NOTE: If the motor floods while attempting to start the trimmer, place the choke lever in the "Run Position", squeeze the throttle trigger and pull the starter rope briskly. The motor should start within 3 to 8 pulls.

After the motor warms up for 5 to 10 seconds, place the choke lever in the "Run Position". Be sure to keep the throttle trigger depressed while warming the motor. Fig 8

NOTE: Choking is not required when starting a warm motor. Start a warm motor in the "Run" position.

To stop the motor depress the Stop Switch. Fig 9

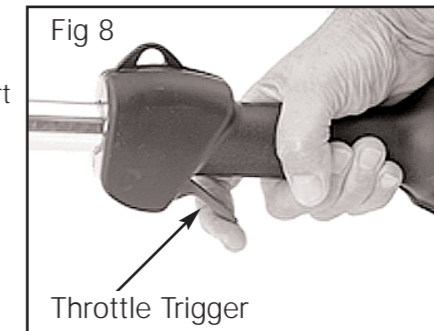

ADJUSTING TRIMMING LINE LENGTH
Your trimmer is equipped with a Bump Feed Cutting Head that allows the operator to release more trimming line without stopping the motor. To release additional line, lightly tap the trimming head on the ground while operating the trimmer at high speed. Fig 10

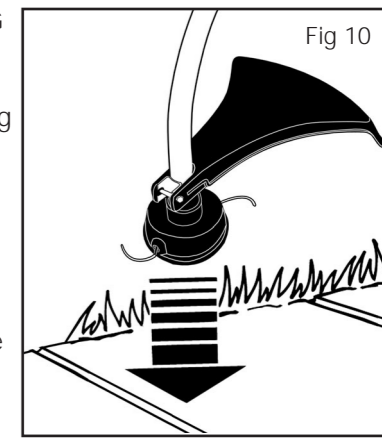

If excess line is released, a blade in the guard will automatically cut the line to the proper length. Fig 11

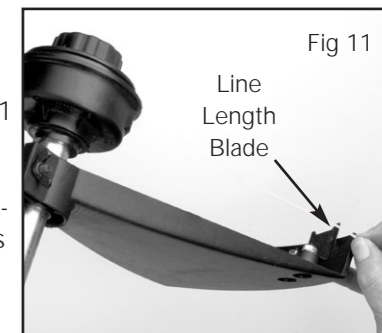

NOTE: Always keep the trimming line fully extended. Line release becomes more difficult as cutting line becomes shorter.

CAUTION: Do not remove or alter the line cutting blade on the guard. Excessive line length will cause clutch to overheat and may result in serious personal injury.

REPLACING EXHAUSTED CUTTING LINE

Remove bump head knob by turning anti-clockwise. Remove spool and spring from spindle. Fig 12.

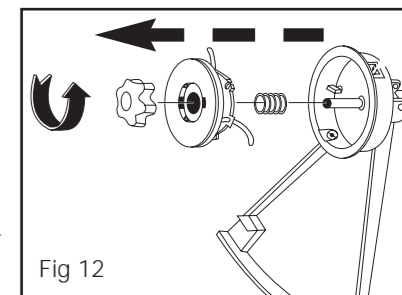

Cut 2 x 2.2m lengths of cutting line and insert one end of each line into the two spool holes as illustrated in Fig 13.

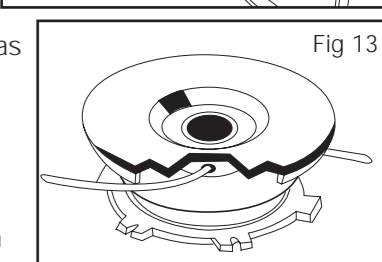

Wind cutting lines clockwise as illustrated in Fig 14, with each line separated by the spool divider. Wind to within 15 cm of the end of the line.

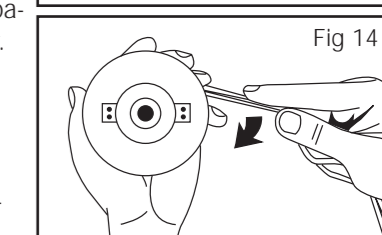

Lock each end of the cutting line into the slots on opposite sides of the spool as illustrated in Fig 15.

